

# TECHINCAL DETAILS

## OF

### *digiTWIST*

### *(Electronic Digital Twist Tester)*

## 1. INTRODUCTION

Twist is the helical disposition of fibers in the yarns to hold up the fibers together to form a yarn. Twist is apparently directly proportional to the strength of a yarn so it is a very important parameter of yarn quality.

**Paramount digiTWIST™** automatically measures the twist of single, double & open-end yarns.

## 2. INTRODUCTION

**PARAMOUNT digiTWIST™** consists of a fixed base on which the main scale is provided to set the length of the specimen yarn. A panel board is mounted on the right hand side of the base to control and perform all operations of the instrument.

On the left hand side of the base, the tensioning device is provided to hold the yarn. This tensioning device is mounted on a moving carriage having stationery yarn gripper Jaw, elongation scale, tension (elongation relief) stoppers and a tension weight pan. The moving carriage can be adjusted upto 20 inches/50 cms. to set the length of the specimen yarn. A Carriage knob is provided on the moving carriage to lock it at any required gauge length. The rotating jaw (gripper) is mounted on left hand side of the control unit which is directly coupled with a high procession DC motor. A spring loaded jaw is provided in the rotating jaw to hold the specimen yarn. A knurled rotary knob is fixed with the rotating jaw for manual rotation. A Fine speed controller is provided to adjust the speed of rotating jaw.

A separate yarn bobbin stand is supplied to rest and draw the specimen yarn while testing.



Corporate Member



Life Member



Member : Bureau of  
Indian Standards

### 3. DETAILS OF THE MAIN UNIT OF *digi*TWIST (*Electronic Digital Twist Tester*)

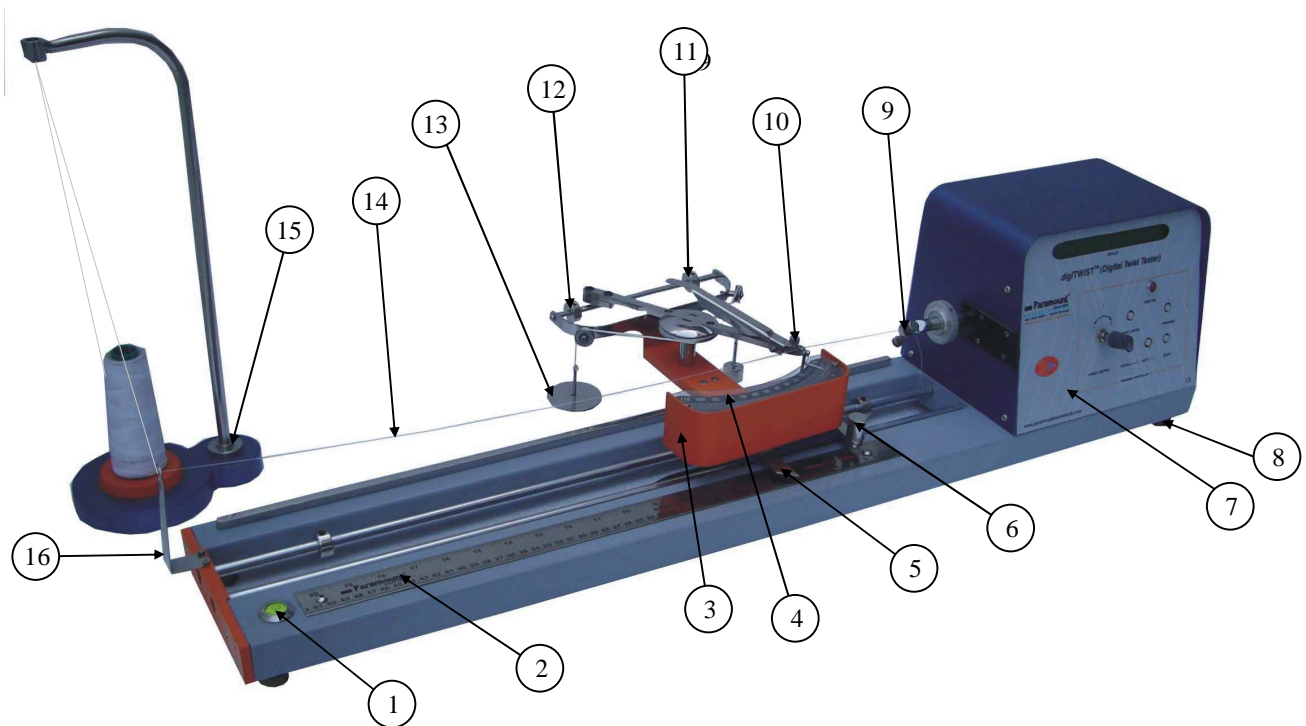

1. Spirit Level.
2. Scale.
3. Carriage Unit.
4. Elongation Scale.
5. Pointer.
6. Carriage knob.
7. Control Panel.
8. Foot Rests.
9. Rotating Jaw (Gripper).
10. Stationary Yarn Gripper Jaw.
11. Pulley for Holding Balancing Pan Unit.
12. Stopper for Rotating Jaw Gripper.
13. Balancing Pan Unit for keeping tension weight.
14. Testing Yarn Specimen.
15. Yarn Cone Stand.
16. Thread Guide Bush.



Corporate Member



Life Member



Member : Bureau of  
 Indian Standards

#### 4. DETAILS OF THE ACCESSORIES SUPPLIED WITH *digiTWIST (Electronic Digital Twist Tester)*

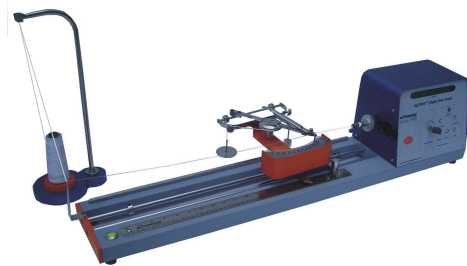

**Main Unit**



Tension Weight For 1 gm. to 50 gm.



Cone Stand Unit



Tension Weight Balancing Pan



Box for Weight



Pointing Needle



Extra Fuse 0.8 Amp.



Spring for Jaw



Extra Thread for Balancing Pan Unit



Rubber Washer for Jaw



Mains Lead



Fine Cutting Scissor



This User's Manual

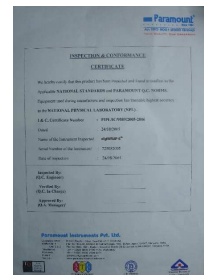

Inspection & Conformance Certificate



Corporate Member



Life Member



Member : Bureau of Indian Standards

**digiTWIST (Electronic Digital Twist Tester) is Supplied Complete with below Accessories:**

1. Main Unit	:	01 No.
2. Cone Stand Unit	:	01 No.
3. Tension Weight For 50 gm.	:	01 No.
4. Tension Weight For 20 gm.	:	02 Nos.
5. Tension Weight For 10 gm.	:	01 No.
6. Tension Weight For 5 gm.	:	01 No.
7. Tension Weight For 2 gm.	:	02 Nos.
8. Tension Weight For 1 gm.	:	01 No.
9. Tension Weight Balancing Pan unit (set of 2 Nos.)	:	01 No.
10. Weight Box for keeping tensins weight	:	01 No.
11. Extra Thread for Balancing Pan Unit	:	01 No.
12. Mains lead with plug	:	01 No.
13. Spring for Jaw	:	02 Nos.
14. Fine Cutting Scissor	:	01 No.
15. Extra Fuse (0.8 Amp.)	:	02 Nos.
16. Pointing Needle	:	01 No.
17. Rubber Washer grip for Jaw	:	02 Nos.
18. This User's Manual	:	01 No.
19. Inspection & Conformance Certificate	:	01 No.

## 5. SALIENT FEATURES

- Latest microprocessor based equipment used to determine the twist per inch/cm.
- Specially designed for single yarn, double yarn & open-end yarns.
- A special sensor for zero setting.
- Special tensioning device provided to give tension to the yarn while testing.
- Totally programmable unit.
- User-friendly control panel, which guides the operator to undertake all steps for testing.
- Smooth precision-engineered auto mechanism.
- 1 to 50gms weight supplied to give proper tension during testing.
- Digital control panel with 40-character, 2 line LCD display.
- Knurled rotating jaw for easy manual rotation.
- A specially design yarn bobbin stand is supplied to rest and draw the specimen yarn while testing.
- Supplied with calibration & inspection certificate.



Corporate Member



Life Member



Member : Bureau of  
 Indian Standards

## 6. TECHNICAL DETAILS OF *digiTWIST (Electronic Digital Twist Tester)*

Power Supply	:	220 / 230V, 50 Hz. AC Single Phase.
Display	:	Microprocessor based LCD digital display (running)
Maximum Test Length	:	50 cm/ 20 Inch.
Tension Weight	:	1gm, 2gm, 5gm, 10gm, 20gm, 50gm. (For set the Tension of 1 gm to 150gm.)
Dimensions (Net)	:	970 x 330 x 220 mm
Weight	:	16 Kg.
Packed Dimensions (Export)	:	1120 x 480 x 370 mm
Gross Weight (Export)	:	14 Kg. (30.8 lb)

## 7. RELATED STANDARD

ISO 2061  
BS 2085  
ASTM 1422/1423  
DIN 53832  
IWTO – 25 – 70

**NOTE :** *With our constant endeavour to improve & excel, we reserve the right to alter the specification or modify the appearance without notice.*



Corporate Member



Life Member



Member : Bureau of  
Indian Standards